

MANUFACTURED IN
NORTH AMERICA

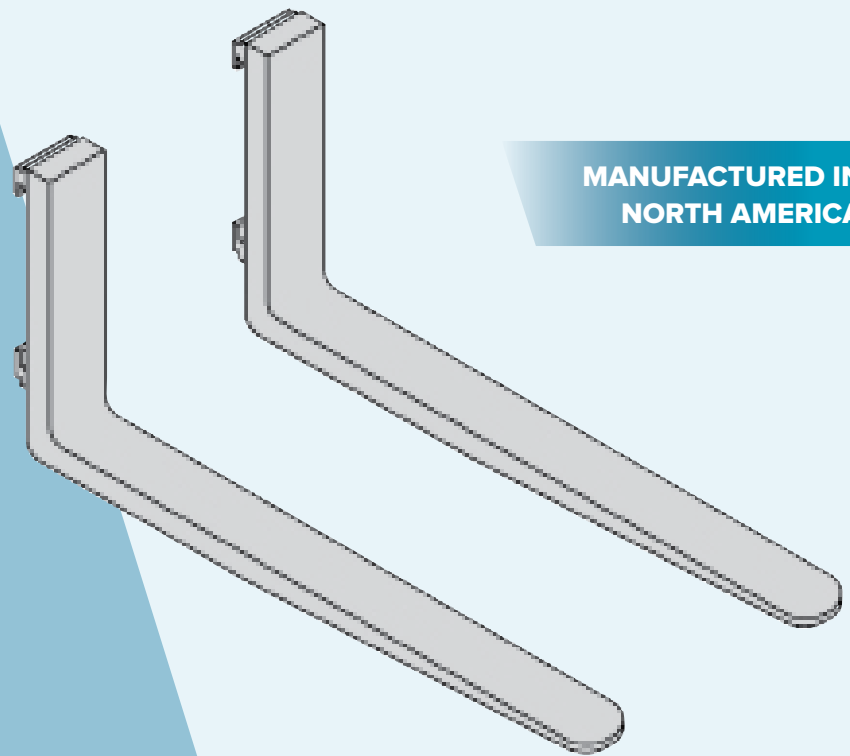

ITA FORKS

Clip-mount forks — also known as ITA Forks — are ideal for warehouse forklifts.

- ➔ Forged from heat-treated premium carbon-steel
- ➔ Greater strength and more resistance to bending
- ➔ Fork life is rated to at least 1 million lift cycles

6 REASONS STAR FORKS ARE BETTER

- 1 **Local manufacturing.**
All forks are manufactured in North America and only from high-grade certified materials.
- 2 **No shortcuts.**
All forks are forged from a single piece of steel, then fully heat-treated, quenched and tempered for a minimum yield strength of 825 Mpa.
- 3 **Certified production methods.**
Welding processes are certified in accordance with ISO 3834-2.
- 4 **Rigorous testing.**
Fork heels and welds are subjected to full MPI crack-testing on all welds and the heel area by certificated operatives.
- 5 **Full part traceability.**
Each fork is stamped with manufacturer's identification, specified capacity and load centre, week of manufacture and production works order number.
- 6 **Standards-compliance.**
All forks are guaranteed to meet or exceed the requirements of the national and (such as ISO2328 and ISO2330 and ANSI ITSDF B56.11.4) with regards to mounting details, load-, fatigue- and impact-tests.



4101 Garland Drive Fort Worth TX 76117
Phone | 817-485-6073 Fax | 817-428-6008
USA & Canada Toll Free 800-541-1797

www.starindustries.com
Operating Manual and Safety Information available online.